

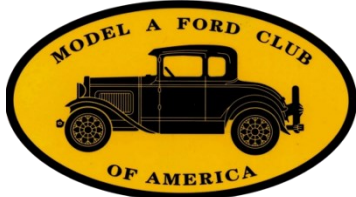

SANTA MARIA A'S HEADLIGHT HERALD

The Santa Maria A's Chapter (Est. 2003), Model A Ford Club of America
Visit our website: www.santamariamodelaclub.com



www.mafca.com

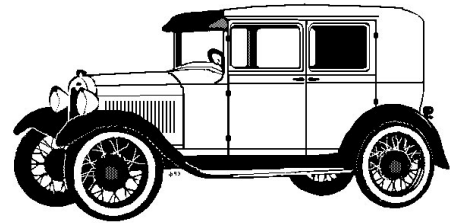

The Santa Maria A's P.O. Box 2983 Santa Maria, CA 93457

August Club Activities

8th -General Club Meeting BBQ Pot Luck (Bring Salad or Side Dish. Honoring our Scholarship Recipients

10th Club Tour to Lavonne Martins Garage Meet at Golden Donut 10:00 RSVP top Roberta by August 5

15th Board Meeting at Giavanni's Pizza, 5:30 Meal, 6:00 Meeting

23rd Newsletter deadline for September Articles, Pictures, Classified

22th Club Breakfast The Boy's Restaurant 8:30 All Welcome!

September Look ahead

September 14th. 22nd Annual All Ford Car Show. See you in Santa Maria

September 24th Los Alamos Old Days Car Show

Please Note: The August Meeting Program will feature Our Scholarship Winners and a BBQ
Deadline for Raffle Prize donations

The Santa Maria A's General meetings are held on the 2nd Thursday of each month at the Elwin Mussell Senior Center, 510 E. Park Ave in Santa Maria, CA. Doors open at 6:00 and the meeting begins at 6:30 PM.

Board of Directors

President : Bill Hansen 805-757-1815

V President: Richard Alexander 805-452-5205

Secretary: Karen Haugse See Roster

Treasurer: Dave Richards 949-606-6788

Activities : Roberta Weber 805-717-9367

Editor: Kay McCord 805-598-8131

Past President Jay McCord 805-598-8133

Members at Large

Lavonne Martin: 805-844-5802

Robert Franzen 805-929-2224

President's Corner

August 2024



President

Hello Santa Maria A's

I can't believe that August is here already. Some of our school kids are starting back to school on the 5th, others begin within the following two weeks. It appears that school starting after Labor Day is but a distant memory for some. What a world we live in.

For the July tour we participated in the Solvang 4th of July Parade and the Hauge's Barbeque. We had 12 cars participating in the parade. I want to thank Hank and Karen for opening their home to us and sharing great food and fellowship with our friends.

We will have a Barbeque Burger night for our next General Meeting, Thursday August 8. The club will provide the burgers with condiments, water and a cake. You can bring a salad or dessert to share if you wish, but it's optional. Our Hancock Scholarship students have been invited. I hope they will share a bit of their story with us. General business will be on the light side. We will be long on chatter and fellowship. We will of course have the 50/50 draw and raffle.

We need your donation for the **Santa Maria All Ford Car Show**. We will be collecting donations for the raffle at the meeting. We need them no later than August 8th. If you can't make the meeting, please drop your donations off at the McCord residence. If transportation is an issue, call me. I would be happy to arrange a pickup. Thank you for your support!

Our August Tour will be a garage tour at Lavonne Martin's home in Nipomo. This should be a great time. Please read the newsletter for details. Happy Trails my friends!! How about driving your A to the August Meeting? We love to see them. See you there!

Bill Hansen

August Celebrations



1-Sally Antram
11-David Richards
14-Liz Poncetta
17 Judy Nobriga
20-Joanna Sumrall

31-Rogerta Weber



12 John & Dianne Humann
26-Sally & Ken Antram



Santa Maria A's General Membership Meeting Minutes July 11, 2024

President, Bill Hansen, opened the meeting at 6:37 p.m. at Elwin Mussell Senior Center in Santa Maria. The sign-in sheet was passed around – 27 attendees. The *Pledge of Allegiance* was led by Richard Alexander.

Missing: *the Club's defibrillator. Contact Bill Hansen.*

Secretary's Report – Karen Haugse. Motion for approval of the (corrected) June 13, 2024 General Meeting Minutes by Jay McCord. Seconded by Mary Denny. Approved.

Correction: Under CCRG Representatives Report, name should read, "David", not Facid.

Treasurer's Report – Dave Richards. Review of Club finances and balances, receipts & checks received. Motion for approval of Treasurer's report – Richard Alexander. Seconded by Jay McCord. Approved.

Activities – Roberta Weber. (See newsletter).

July 11 – General Meeting – Nancy Richards will bring dessert.

July 18 – Board Meeting at Giovanni's Pizza restaurant, Santa Maria. Members welcome.

July 25 – Club breakfast at 8:30, The Boy's Restaurant, Santa Maria.

August 8 – General Meeting/potluck/barbecue – a cake honoring the recent Allan Hancock College Scholarship winners will be provided. (No need for Mary Denny to bring dessert). There will be an exceptional surprise announcement by Kay McCord.

August 8 – **Deadline** for raffle items today – Kay McCord.

August 15 – Board Meeting at Giovanni's Pizza restaurant, Santa Maria. Members welcome.

August 22 – Club breakfast at 8:30, The Boy's Restaurant, Santa Maria.

Newsletter – Kay McCord.

Article deadline for the *Santa Maria A's Headlight Herald* newsletter is the first Tuesday after the Board Meeting. Do you have a story to share – 500 words or less? Do you have a car or parts for sale? Note: if your item has sold or there are ad changes, please let Kay know.

Old Business:

Curt Warner needs more volunteers for the Car Show. A signup sheet was passed around. Jay McCord brought car show posters for distribution.

E-mail Robert Franzen with your odometer readings to qualify for a mileage patch.

New Business:

Kathy Pedrick announced the 2024 Old Days Car Show in Las Alamos on September 28.

Gary Lees won the 50-50 drawing.

Discussion re purchasing a portable loud speaker system – membership unanimously agreed.

Motion for approval of buying a portable loud speaker under \$300 – Curt Warner. Seconded by Ron Stevens. Approved.

CCRG Representatives Report: Curt Warner.

2024 Grand Tour – Monterey Peninsula, September 30 to October 4; registration forms & information are available online. Trudy Stephens talked about the David and Karen Bockman service award.

Program – Gary Lees gave a demonstration on his coil and condenser tester.

Website: See www.SantaMariaModelAClub.com

Let Curt Warner know if you find any inaccuracies on the website.

Sunshine Report: Lavonne Martin will be the contact person re well-being of members. Kathy Pedrick & Linda Phelps will send cards or make telephone calls as needed. Richard Alexander discussed recognizing birthdays each month with singing, *Happy Birthday*, and awarding a free raffle ticket. Members must be present to receive the raffle ticket.

*Reminder: you must be a MAFCA member in order to participate in MAFCA events.

Adjourned at 8:11 p.m. Respectfully submitted by Karen Haugse.

Model A's On Parade!

The Santa Maria A's showed their Patriotic Spirit at the Solvang Fourth of July Parade. Twelve decorated cars proceeded to WOW the crowd along the streets of Solvang amid cheers, clapping, huge smiles and cries of HONK YOUR HORN! We then traveled the short distance to the COOL Home of Hank and Karen for a yummy BBQ, cold drinks, and our annual trivia test complete with prizes. We had a nice turnout of 28. Thank you to Karen, Hank.



Jim's Tech Tips

"Difficult Steering"

Many Model A owners find their car hard to steer when parking or maneuvering at low speed. After you confirm that there is oil in the steering gear box (not grease), the tires are all inflated to 35 psi, and everything on the front axle has been properly greased, you are left with the most likely cause: The spindle bolt (kingpin) "thrust bearings" are defective or they are not shimmed up properly to support the weight of the car. You can confirm this by using a floor jack to take some weight off of the front wheels, and then see if the steering effort is drastically reduced. If it is, the problem is the bearings.

To correct this, you need to remove everything from the spindles to get to the kingpins and remove them. See Les Andrews' Red Book, starting on page 1-209, for directions. The illustration below comes from later in that section.

Clean the thrust bearing and replace it if it does not turn smoothly or shows any signs of wear. Pack the bearing with grease before reinstalling.

When reassembling, you need to test fit the spindle with the kingpin fully locked in place with the locking pin. Temporarily leave the large felt seal and metal washer off of the bottom of the spindle for this. Start with the number of shims previously used, then add 1 shim at a time until very little or no vertical movement of the spindle is felt on the kingpin. It can take up to 4 shims to compensate for wear.

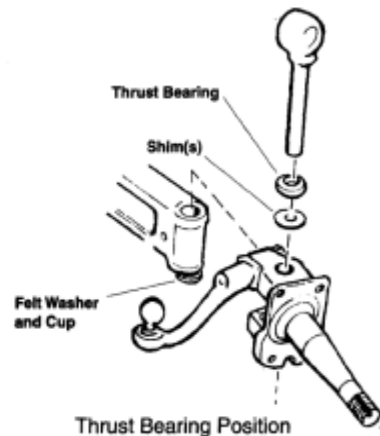

At some point, adding a shim may jam up the spindle, making it hard to turn on the kingpin. If it does, take that last shim out, reassemble, and confirm that the spindle again moves easily, as it should. Now reassemble the spindle on the axle with the felt seal and the cupped metal washer installed between the axle and the bottom part of the spindle (the metal cup touches the axle, the felt touches the spindle). The added thickness of the felt seal may temporarily make the spindle a bit stiff turning on the kingpin, but it will quickly flatten out and move smoothly when you drive.

Now reinstall everything that attaches to the spindle, install the brakes, maybe use this as an opportunity to clean and repack the wheel bearings, then install the drums and the wheels. Grease all of the fittings well. Go for a test drive, enjoy the easier steering, and *Have a Model A Day!*

Jim



“Betsy”, Our Model A

As told by Ron and Trudy

I first fell in love with the Model A Ford when my uncle Bernie’s parents, Roscoe & Mary Smith, had a 1930 Fordor which he bought new. He used it as a taxi in the late 1940’s. Later, Roscoe went blind, and Mary drove it everywhere! Whenever something went wrong with the A Roscoe would fix it, even when he was blind as a bat. He would ask Mary for a tool or wrench, and she would hand it to him to use. I have seen him tune his Model A to a T, and it would run like a charm. I have also seen him fix and repair his brakes. And **THAT**...In the 50’s is when I fell in love with the Model A Ford!

I had always wanted a Model A of my own, but we were raising a family and could not afford one. As soon as our children were out of the house, we bought our first Model A. We still have and enjoy our 1929 Sport Coupe. On our first trip we went to Solvang, and on the way back to Santa Maria we kept having to empty the sediment bowl because it continued filling up with rust. Trudy thought we would never make it home, But we did and then I took the gas tank off and had it repaired. Other improvements were a new engine, a Mitchell Overdrive, and a new set of tires. I also installed a new wiring harness to bring the car up to date. Since we got it up and running, we have driven well over 40,000 miles. Trudy & I love going on tours and Jamborees, and just driving around in our Model A.

Now I am too old to work on our Model A, I can get down, but I cannot get up, but thanks to our Model A friends, we have been able to keep her running.

Thank you, Richard and Brian, and the Santa Maria A’s for all your help.

Ron & Trudy



KARENS FABOLOUS BLUEBERRY PECAN CRUMBLE

INGREDIENTS

TOPPING

1 Cup Chopped Pecan Pieces
1 Cup All Purpose Flour
1¼ Cups Rolled Old Fashioned Oats
½ Cup Packed Dark Brown Sugar

spoons Flour

1 Teaspoon Ground Cinnamon
A Couple Pinches Salt
1 Stick Butter (8 Tablespoons) cut into small pieces

FILLING

4 Cups (Two Pints) Fresh Blueberries
1/2 Lemon, Juiced
3 Tablespoons Sugar
2 Table-

Directions

Preheat oven to 350 degrees.

For topping, put all ingredients into a bowl and rub together with hands until mixture sticks together in small clumps.

Pour the blueberries into a greased 9 x 13-inch baking dish, squeeze the lemon juice over the berries, sprinkle the sugar and flour over them and toss to coat.

Scatter the topping over the berries in an even layer, bake until the topping is golden

Classifieds

For Sale:

1930 Coupe Formerly Al Schirmers Car, Borg Warner Overdrive, Rumble Seat, Call Richard, 17.5K

1931 Pickup, Formerly Al Schirmers Truck, 17.5K Call Richard Alexander 805-452-5205

1940 Ford V8, 4 door Sedan, 20k OBO Call Richard Alexander 805-452-5205

1930 Briggs Town Sedan with 55k Original Miles. This is a very solid original car Clean title with Year of Manufacture plates, rebuilt engine by Aaron Machado in Santa Barbara, and much more, Purchased new in San Fernando Valley, 10k obo Contact Keith Struve 805-868-0131

1935 Ford Four door sedan, In beautiful condition, This is a solid Touring car for touring Asking 20K
Contact Chris Tiffany, 805-588-8913

1935 Ford 5 window Coupe. It's a beautiful black coupe, Kelsey Hayes wheels, 6 volt with electric fuel pump, Price reduced to 26K, Contact Chris Tiffany 805-588-8913

1926 Model T Roadster Pickup, Very Original, Older Restoration, No Rust, in very nice shape. Of course its Black. Wooden wheels. It's a beauty. Ran when parked. Asking 12k Chris Tiffany 805-588-8913

22nd Annual All Ford Car Show and Swap Meet



Celebrating Flathead V-8's 1932-1953



Benefits Allan Hancock College Industrial Technology and Other Local & National Scholarships

Saturday September 14, 2024

Car Show • 9 am-3 pm | Swap Meet 7 am

AWARDS • RAFFLE PRIZES • 50/50 • MUSIC • Non-Food Vendors Welcome!

ENTRY APPLICATIONS AVAILABLE AT: www.santamariamodelclub.com

Old Town Orcutt

at the Orcutt Union Plaza • 201 S. Broadway, Orcutt, CA 93455

Contact Jay McCord (805) 598-8133 • Curt Warner (805) 478-1231

CONTRIBUTING SPONSORS



22nd Annual All Ford Car Show & Swap Meet

Saturday, September 14, 2024—9 am-3 pm

In Old Town Orcutt

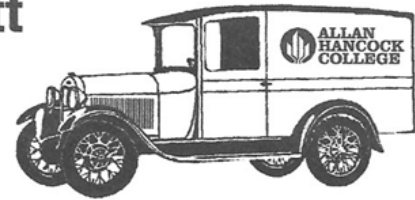
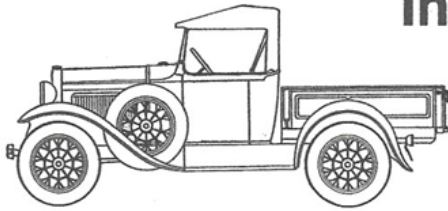

SPONSORED BY:

The Santa Maria A's
 Registration \$30.00 prior to Sept. 1
 \$40.00 After the 1st. & day of show.

For information contact
 Jay McCord (805) 598-8133
 • jemccord@aol.com
 or Curt Warner (805) 478-1231
 • Ckw71977@gmail.com

www.santamariamodelaclub.com

Non-Food Vendors Welcome

• SWAP MEET:

Registration 6:30 AM
 Opens to the Public 7:00 AM

• CAR SHOW:

Car Registration 7:00-9:00 AM
 Raffle Prizes begin at 10:00
 Car voting ballots in by 12 Noon
 Trophies at 2:00
 50/50 Drawing at 2:30

NO FIREARMS/ALCOHOL

Supporting Allan Hancock Automotive Technology and other Local & National Scholarships

**REGISTRATION FORM: Make checks to
 Santa Maria A's, PO Box 2983, Santa Maria, CA 93457
 PLEASE PRINT CLEARLY!!!**

Name: _____ Phone: _____

Address: _____

City: _____ State: _____ Zip: _____

E-Mail: _____

Year: _____ Make: _____ Model: _____

Club: _____ Class: _____

Show Car/Truck: _____ OR: Swap Meet: _____ OR: Vendor: _____

Class will be determined by show criteria (see reverse). Ask if you have any questions.

Signature Required Here

Liability Release:

In consideration of the acceptance of the right to participate, entrants and spectators, by the execution of this entry form, release and discharge the Santa Maria A's, from any and all damages, injuries, losses, judgments and/or claims from any cause whatsoever that may be suffered by any entrant, to his person or property. Further, each entrant expressly agrees to indemnify all of the forgoing entries, firms, and persons and bodies of and from any and all liability occasioned or resulting from the conduct of entrants or any participant assisting or cooperating with the entrant and under the direction or control of the entrant. I also give permission for my entry vehicle and my person to be photographed at the car show for use in any form of future communication or advertisement.

22nd Annual All Ford Car Show & Swap Meet



Saturday, September 14, 2024 — 9 am-3 pm
In Old Town Orcutt

201 South Broadway, Orcutt, CA 93455

Class 1: Ford/Lincoln-Open Vehicle-Original 1903-1931

Class 2: Ford/Lincoln-Open Vehicle-*Modified 1903-1931

Class 3: Ford/Lincoln-Closed Vehicle-Original 1903-1931

Class 4: Ford/Lincoln-Closed Vehicle-*Modified 1903-1931

Class 5: Ford/Lincoln/Mercury-Original Vehicle 1932-1947

Class 6: Ford/Lincoln/Mercury-*Modified Vehicle 1932-1947

*Modified--A Vehicle in which the body and/or drivetrain have been substantially modified from original.

Class 7: Ford/Lincoln/Edsel/Mercury-All Except Mustang/Cougar/Truck-1948-1973

Class 8: Ford & Mercury Trucks/Rancheros-1948-1973

Class 9: Mustangs/Shelbys/Cobras 1963-1973

Class 10: Mustangs/Shelbys/Cobras 1974 & newer -- includes replicars, kit cars, etc.

Class 11: All Ford Vehicles- except Mustang/Shelby/Cobra/Cougar -- 1974 & newer -- includes replicars, kit cars, etc.

Class 12: Cougars 1967-1997

- Best Club Participation Award
- Participants Choice Award for Best of Show
- Chuck Bailey Award for Best Original Model A Ford
- Best Feature Car Award

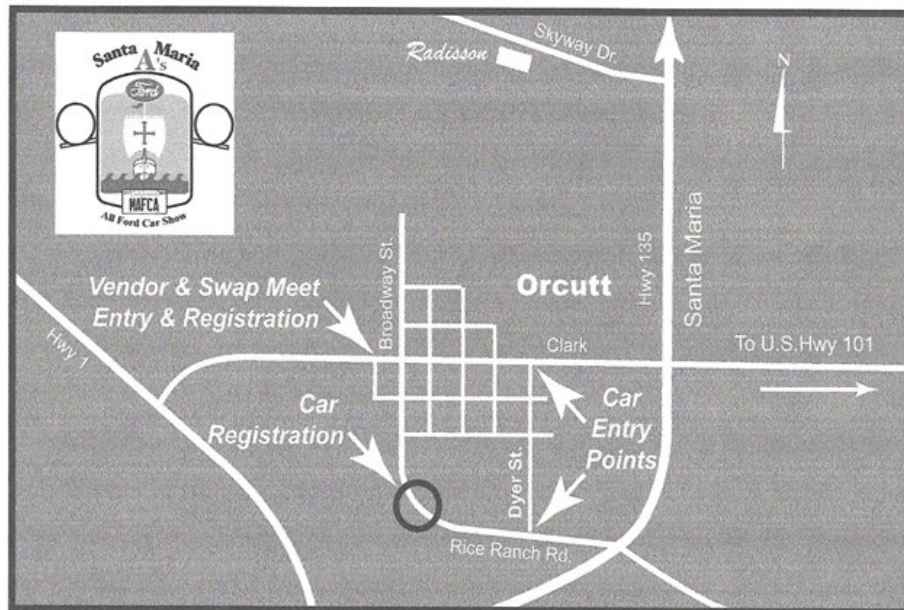

DIRECTIONS: Exit Hwy. 101 at Clark. Go West to Dyer St. in Old Town Orcutt. Turn left to Rice Ranch Road. Turn right on Rice Ranch Road, proceed to Car Show entry point.

Stay at the

Radisson

Hotel Santa Maria

3455 Skyway Drive, Santa Maria Ca 93455
Call (805) 928-8000 for special rates.

A FEW MORE THINGS...

The Model A Ford Foundation is holding a Sweepstakes Here is the info.

Win "Betsy" a 1930 Ford Model A Sport Coupe – enter sweepstakes to win Betsy, which was donated to raise funds for the expansion of the Model A Ford Museum; Betsy has won 32 top placed trophies in 34 shows.

See website: www.MAFFI.org/Index

Or contact: JarrodWilliams81@gmail.com



Our Mission is to honor all of America's veterans by taking them to Washington D.C. on their "Tour of Honor" as our guest. For information visit the Internet site.

<https://www.honorflightccc.org/>

PUT THIS ON YOUR CALENDAR!!



September 30, 2024

Through

October 1st, 2nd, 3rd

For Our

MONTEREY

“2024 CCRG GRAND TOUR”

We will Begin Our Tour on **September 30th** in
Paso Robles, CA, for a one night stay.

Then we will depart Paso Robles on the morning of
October 1st and will caravan on some picturesque
back farming and country roads, paralleling Highway 101.

After our fun drive we will arrive for lunch in the
Monterey/ Pacific Grove area, in the afternoon, in time to check into
our Hotel where we will begin our stay for
fun-filled days and then departing on **Oct. 4th**.

Linda Jackson, Linda and Phil Kneeland are still in the process of
filling in all of the blanks for this
“FUN FUN” 2024 Grand Tour”!!

Please be checking your Email for more updates as
Linda Jackson, Linda & Phil Kneeland
research more good places to stay, eat and visit!!





Next to Jack's in Old Orcutt

Old Orcutt Barbers

Albert Licerio

156 S. Broadway St. Suite A
Orcutt, Ca 93455

805-937-6575
No Appointments Necessary

BRIAN WEBER
PRESIDENT
24 HR FIELD SERVICE



SANTA MARIA TOOL, INC.
COMPLETE MACHINE SHOP SERVICE
www.santamariatool.com

2326 S. OAKLEY
SANTA MARIA, CA 93455

OFFICE (805) 925-2126
CELL (805) 714-1324
FAX (805) 925-2150

brian@santamariatool.com

ARIZONA MODEL A, L.L.C.

- NEW PARTS
- USED PARTS
- SERVICE
- RESTORATION
- HOUR: TUES-FRI 9-12, 1-5
SAT & EVES BY APPOINTMENT

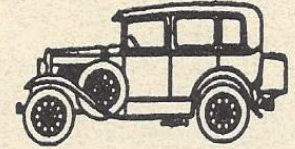

SAMUEL P. GUTHRIE

15838 S. GILBERT RD., CHANDLER, AZ 85225
(480) 782-0266

INDUSTRIAL RADIATOR

Service, Inc.

DOUG JEFFERS
COMPLETE COOLING SYSTEM SERVICE
(805) 928-3848

1625-A E. DONOVAN RD.
SANTA MARIA, CA 93454
P.O. Box 2160
NIPOMO, CA 93444

CELL (805) 431-5276
HOME (805) 489-3478



Next to Jack's in Old Orcutt

Old Orcutt Barbers

Albert Licerio

156 S. Broadway St. Suite A
Orcutt, Ca 93455

805-937-6575
No Appointments Necessary

RENNER'S CORNER

EARLY FORD PARTS

Specializing in 1928 thru 1934
4 cylinder
PARTS & REBUILD KITS

Better than new!

David Renner
734-428-8424

www.rennerscorner.com

Custom Colors

AUTO BODY SUPPLIES INC

315 W. Dal Porto Lane • Santa Maria, California, 93458

Automotive & Industrial Paint
Supplies & Equipment

BUS: (805) 925-0210
BUS: (805) 928-5744
FAX: (805) 928-8124

Yes! We Still Carry Solvent Based Paint!

ALAN TUCK
CELL: (805) 598-2025

FEB California Est. 2009
SANDY'S
REGISTRATION SVC & MORE

SANDY WILEY, OWNER
Ph: 805-896-2220 • Fx: 805-614-9797
703 South Broadway, Santa Maria CA 93454
sandysregsvc@hotmail.com



Waiting in Long DMV Lines!



REGISTRATION RENEWALS W/STICKERS & PLATES HANDED TO YOU! NO APPT NECESSARY